

# OWNERS MANUAL

**Model No.  
45-02101-101**

CAUTION:  
Read Rules for  
Safe Operation  
and Instructions  
Carefully

- Assembly
- Operation
- Maintenance
- Repair Parts



## PRO 125# BROADCAST SPREADER

# TABLE OF CONTENTS

SAFETY RULES.....	2	MAINTENANCE & STORAGE.....	9
CARTON CONTENTS.....	2	LUBRICATION.....	9
ASSEMBLY.....	4	PARTS EXPLOSION.....	10
OPERATION.....	8	REPAIR PARTS.....	11

## RULES FOR SAFE OPERATION

Any power equipment can cause injury if operated improperly or if the user does not understand how to operate the equipment.

Exercise caution at all times, when using equipment.

1. Do not allow anyone to operate the broadcast spreader without proper instructions.
2. Do not permit children to operate the broadcast spreader.
3. Wear eye protection when handling and when applying lawn chemicals.
4. Read the product label for instructions and cautions on proper handling and application of lawn chemicals.
5. Keep all nuts, bolts and screws tight to be sure equipment is in safe working condition.
6. Follow maintenance and lubrication instructions as outlined in this manual.



**LOOK FOR THIS SYMBOL TO POINT OUT IMPORTANT SAFETY PRECAUTIONS. IT MEANS -- ATTENTION! BECOME ALERT! YOUR SAFETY IS INVOLVED.**

## CARTON CONTENTS (LOOSE PARTS IN CARTON)

Your broadcast spreader carton contains parts as shown in the carton contents diagram below. The hardware package contains parts shown on page 3. Identify all parts and lay out as shown.

- |                       |                                |
|-----------------------|--------------------------------|
| 1. Hopper Assembly    | 8. Hopper Screen               |
| 2. Drive Wheel        | 9. Handle Tube (Short)         |
| 3. Idler Wheel        | 10. Flow Control Arm           |
| 4. Spreader Shield    | 11. Handle Tube (Long)         |
| 5. Braces             | 12. Leg Stand Tube             |
| 6. Flow Control Rod   | 13. Flow Control Gauge         |
| 7. Vinyl Hopper Cover | 14. Flow Control Mount Bracket |

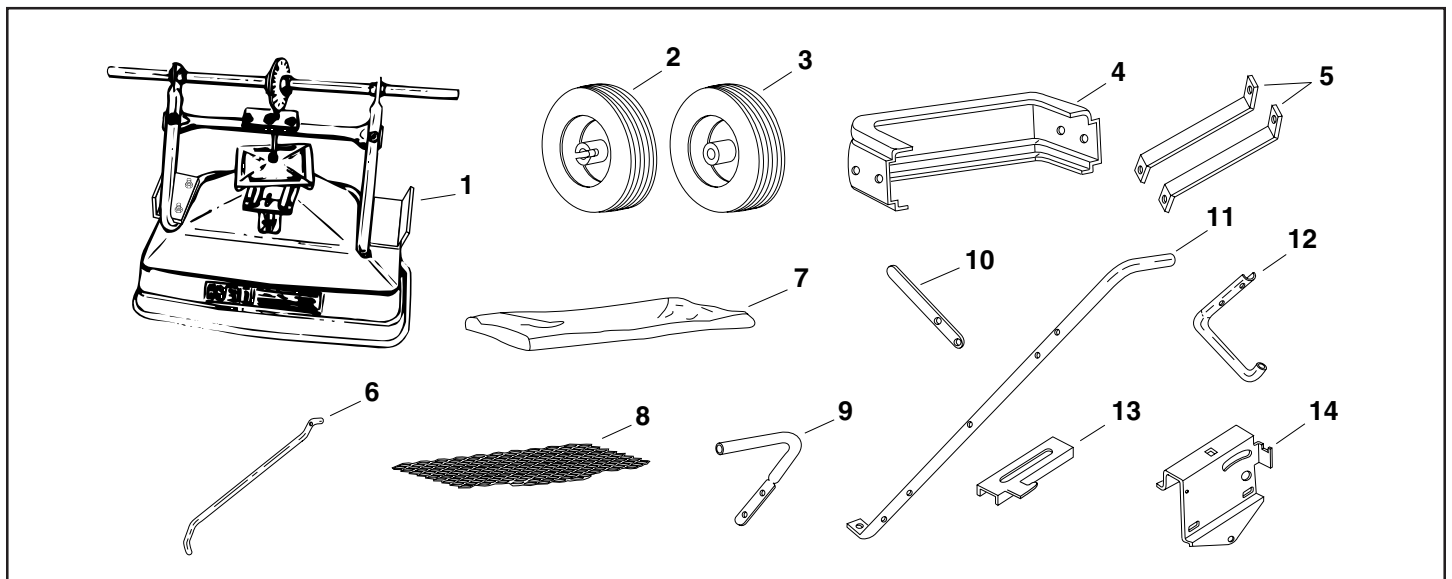

**CARTON CONTENTS**

## FULL SIZE HARDWARE REFERENCE CHART

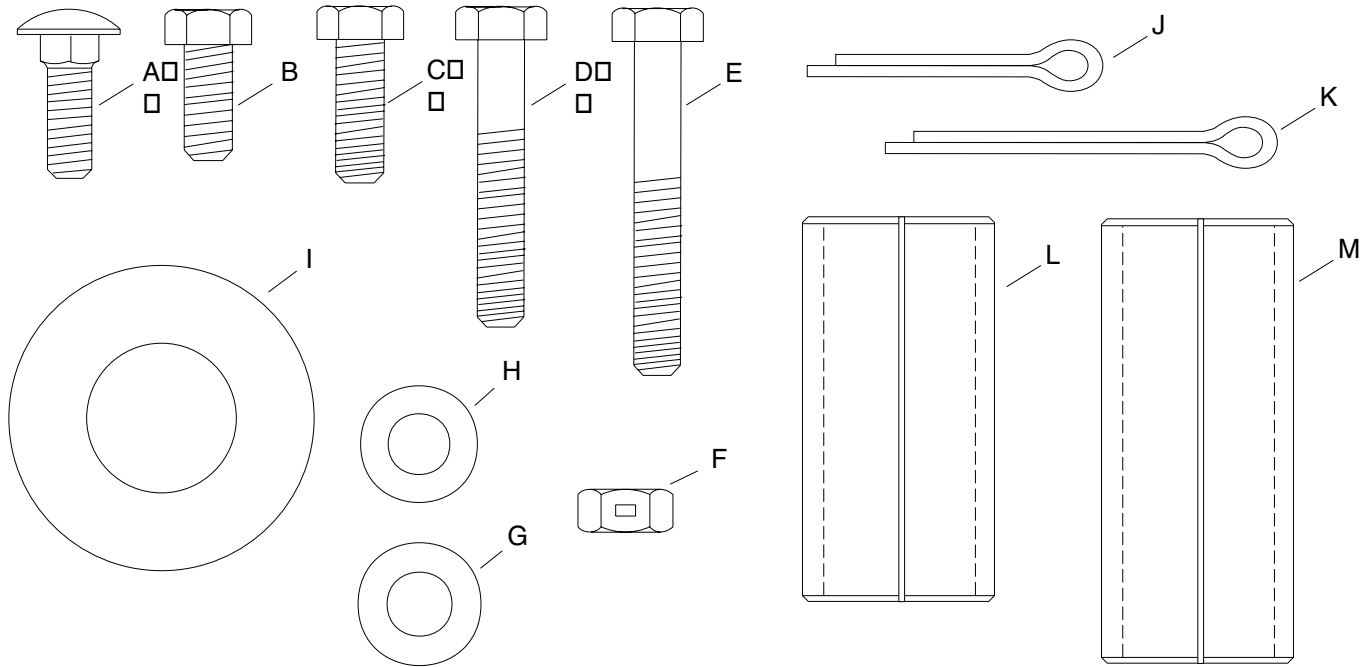

### NOT SHOWN FULL SIZE

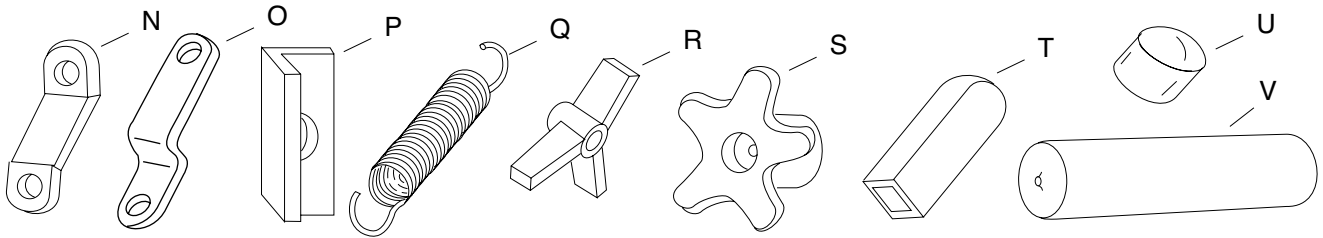

REF.	QTY.	DESCRIPTION	REF.	QTY.	DESCRIPTION
A	3	Bolt, Carriage 1/4" x 3/4"	L	1	Spacer Tube, Short (1")
B	2	Bolt, Hex 1/4" x 5/8"	M	1	Spacer Tube, Long (1-5/16")
C	6	Bolt, Hex 1/4" x 3/4"	N	4	Bracket, Swivel
D	2	Bolt, Hex 1/4" x 1-1/2"	O	1	Link, Flow Control
E	6	Bolt, Hex 1/4" x 1-3/4"	P	2	Bracket, Angle Stop
F	16	Nut, Hex Lock 1/4-20	Q	1	Spring, Extension
G	17	Washer, 5/16"	R	1	Knob, Hand
H	5	Washer, Nylon	S	2	Knob, Plastic 1/4"
I	4	Washer, 3/4"	T	1	Grip, Control Arm
J	1	Cotter Pin, 3/32" x 3/4"	U	1	Cap, Vinyl
K	1	Cotter Pin, 1/8" x 1-1/2"	V	2	Grip, Handle

# ASSEMBLY INSTRUCTIONS

## TOOLS REQUIRED FOR ASSEMBLY

- (1) Pliers
- (2) 7/16" Open End or Box Wrenches
- (2) 9/16" Open End or Box Wrenches

## REMOVAL OF PARTS FROM CARTON

Refer to carton contents on page 2 and to the hardware chart on page 3 to lay out and identify parts and hardware needed to assemble the spreader.

## ASSEMBLY OF SPREADER

1. Place the spreader upside down.
2. Assemble the long spacer tube and a 3/4" washer onto the end of axle of the axle that has the small drilled hole (right hand side). See figure 1.
3. Place the idler wheel (no notch in hub) onto the axle. The air valve should face to the outside. See figure 1.
4. Assemble one or two more 3/4" washers onto the axle and then assemble the 1/8" x 1-1/2" cotter pin.

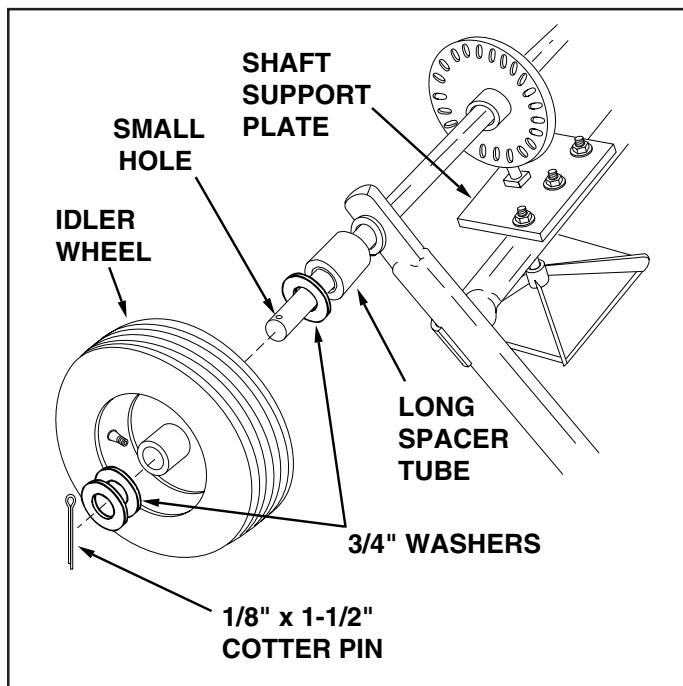

FIGURE 1

5. Place the short spacer tube and a 3/4" washer onto the end of the axle that has the large drilled hole (left hand side). See figure 2.
6. Place the drive wheel onto the axle. The notched hub and the air valve should face to the outside. See figure 2.
7. Fasten the wheel to the axle using a 1/4" x 1-3/4" hex bolt and a 1/4" hex lock nut. See figure 2.

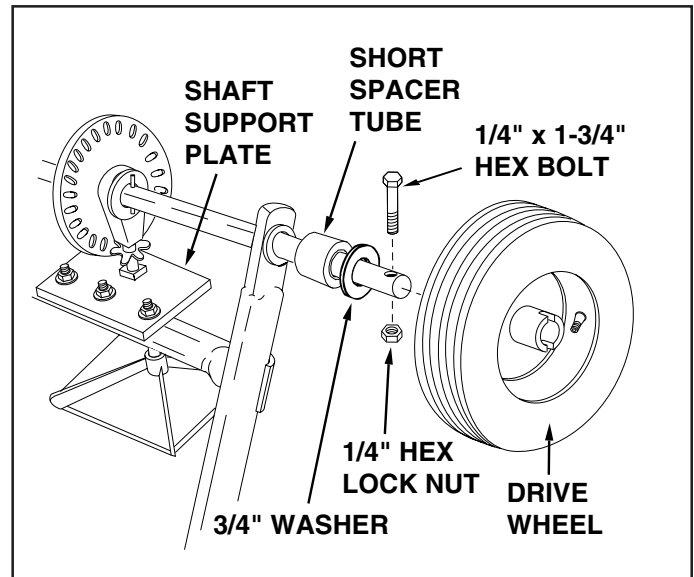

FIGURE 2

8. Tip the spreader over to rest on the front edge of the hopper and on the wheels.
9. Remove the middle 3/8" hex bolt, flat washer and hex lock nut that fasten the shaft support plate to the crossover tube. **Do not loosen or remove the two outer bolts.** See figure 3.

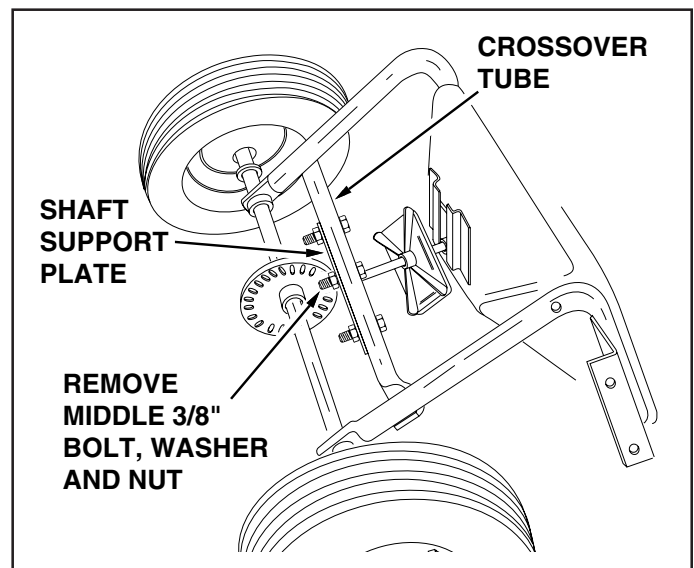

FIGURE 3

10. Assemble the (long) handle tube to the side of the crossover tube opposite the shaft support plate, as shown in figure 4. Fasten the handle tube to the middle hole using the bolt, flat washer and hex lock nut which you removed in step 9. **Do not tighten yet.**

**IMPORTANT: DO NOT** assemble the handle tube to the side of the crossover tube where the shaft support plate is located. When the spreader is placed in the upright position, the handle tube must be on to the top side of the crossover tube. Refer to figure 17 on page 9.

11. Assemble the end of a handle brace to the inside of each leg of the hopper tube frame, using a 1/4" x 1-3/4" hex bolt and 1/4" lock nut for each brace. See figure 4. **Do not tighten yet.**

12. Assemble the other end of both handle braces to the handle tube using a 1/4" x 1-3/4" hex bolt and 1/4" hex lock nut. **Do not tighten yet.** See figure 4

13. **Tighten** in sequence the bolts and nuts that were assembled in steps 10, 11 and 12.

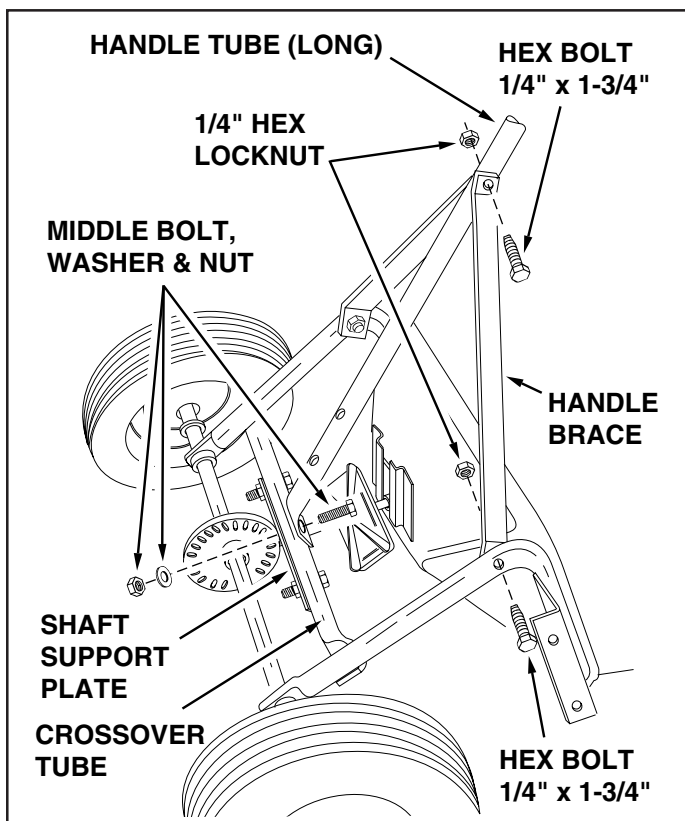

FIGURE 4

14. Assemble the leg stand tube to the handle tube (long) using two 1/4" x 1-1/2" hex bolts and two 1/4" hex lock nuts. **Tighten.** See figure 5.

15. Place the vinyl cap on the leg stand tube. See figure 5.

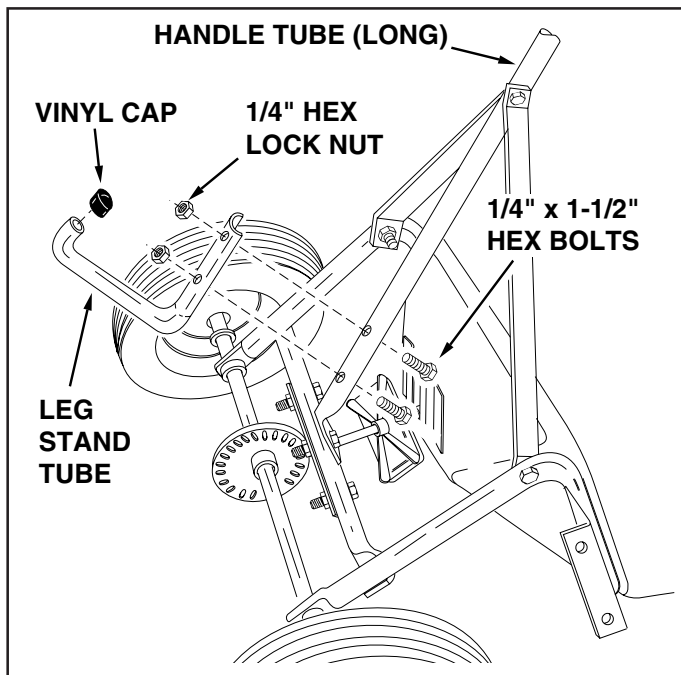

FIGURE 5

16. Assemble the flow control link (the long end with the small hole) to the flow control arm using one 1/4" x 5/8" hex bolt and one 1/4" hex lock nut. **Do not over tighten.** The flow control link must pivot freely. See figure 6.

17. Place the vinyl grip on the flow control arm. See figure 6.

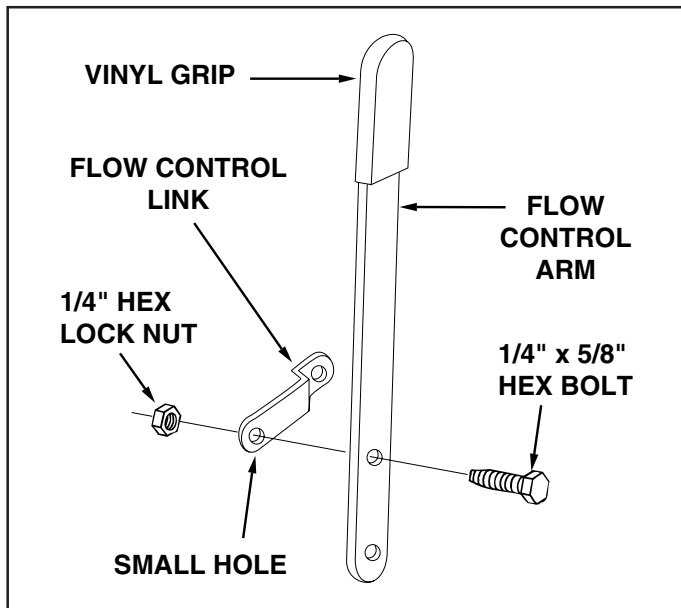

FIGURE 6

18. Assemble the flow control arm to the flow control mounting bracket using one 1/4" x 5/8" hex bolt and one 1/4" hex lock nut. **Do not over tighten.** The flow control arm must pivot freely. See figure 7.

19. Hook one end of the spring through the hole at the bend in the flow control rod. Hook the other end in the hole in the flow control mounting bracket. See figure 7.

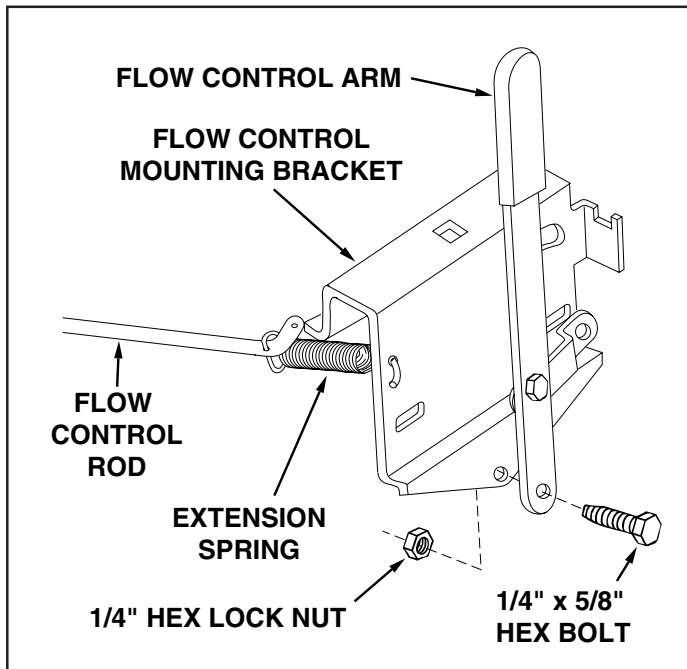

FIGURE 7

20. Place a 5/16" flat washer over the end of flow control rod and insert the rod through the slot in the flow control mount bracket and through the hole in the flow control link. Secure with a 3/32" x 3/4" cotter pin. See figure 8.

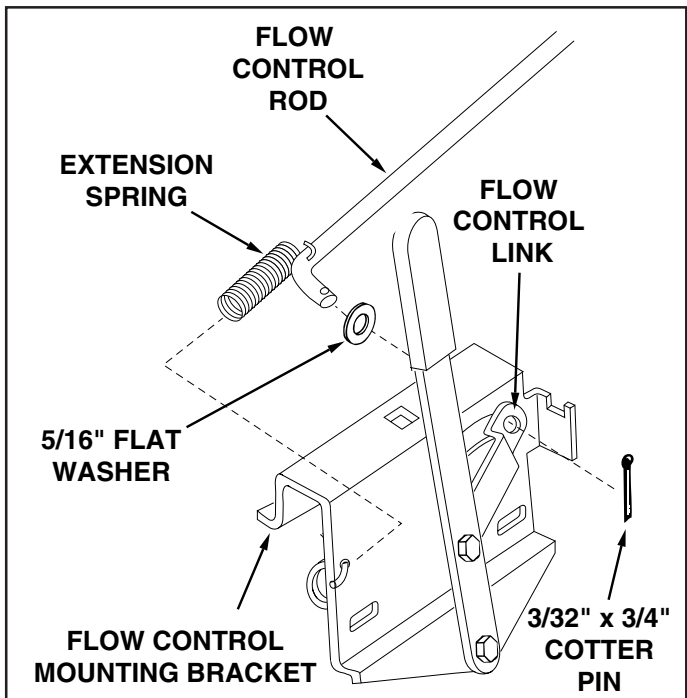

FIGURE 8

21. Hook the free end of the flow control rod through the hole in the slide gate bracket located near the bottom of the hopper. See figure 9.

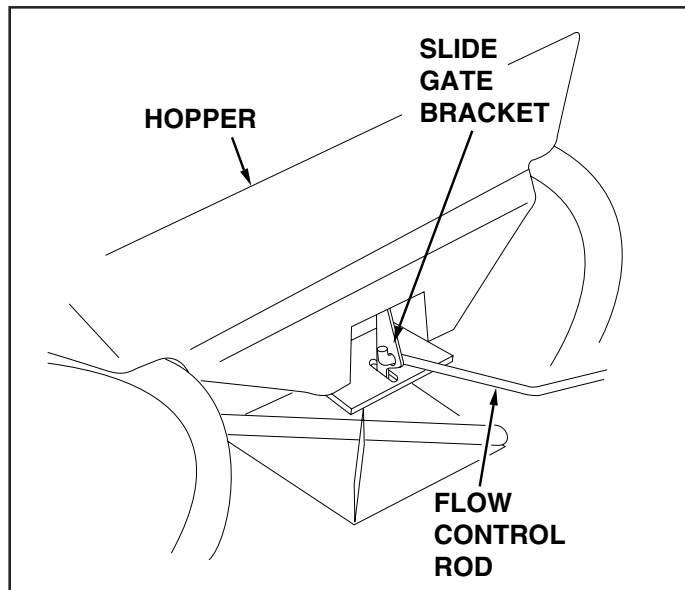

FIGURE 9

22. Assemble the flow control mounting bracket and the short handle tube to the long handle tube using two 1/4" x 1-3/4" hex bolts, two 5/16" flat washers and two 1/4" hex lock nuts. See figure 10. **Do not tighten yet.**

23. Place a handle grip on each handle tube. See figure 10.

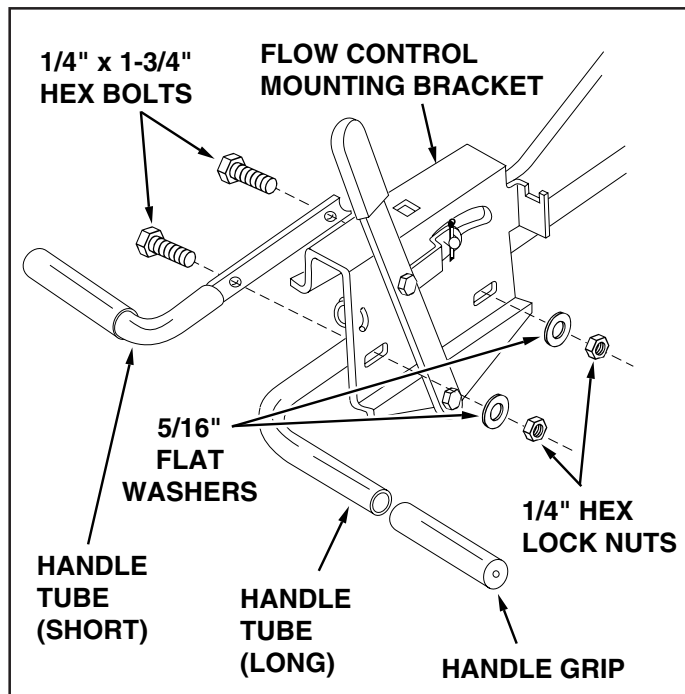

FIGURE 10

24. Assemble the flow control gauge onto the flow control mounting bracket using a 1/4" x 3/4" carriage bolt, a nylon washer and the hand knob. See figure 11.
25. Push the flow control arm forward to the off position and slide flow control mounting bracket toward hopper until closure plate (bottom of hopper) is fully closed. Carefully tighten the 1/4" hex lock nuts without deforming the slots. The closure plate should open half way when the flow control gauge is set at "5". Reposition the flow control mounting bracket as necessary. See figure 11.

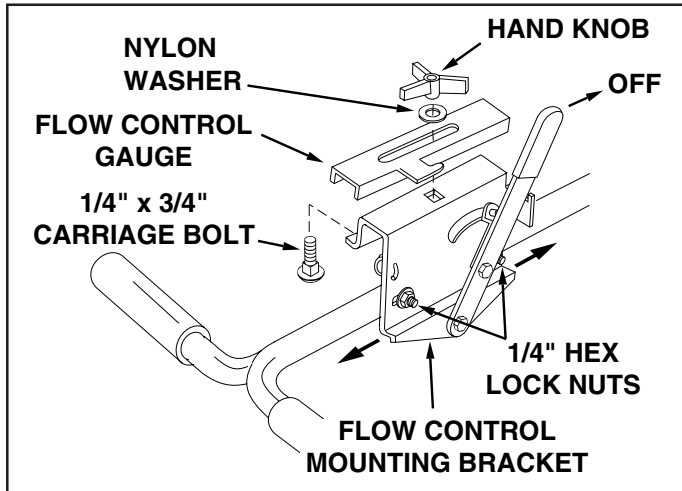

FIGURE 11

26. Attach an angle stop bracket (inside) and a swivel bracket (outside) to the rear hole in the R.H. shield bracket using a 1/4" x 3/4" hex bolt, two 5/16" washers, a nylon washer and a 1/4" hex lock nut. **Tighten** the locknut so that the swivel bracket can pivot freely. See figure 12. Repeat step on L.H. shield bracket.
27. Attach a swivel bracket to the front hole in the R.H. shield bracket using a 1/4" x 3/4" hex bolt, two 5/16" washers, a nylon washer and a 1/4" hex lock nut. **Tighten** the locknut so that the swivel bracket can pivot freely. See figure 12. Repeat step on L.H. shield bracket.

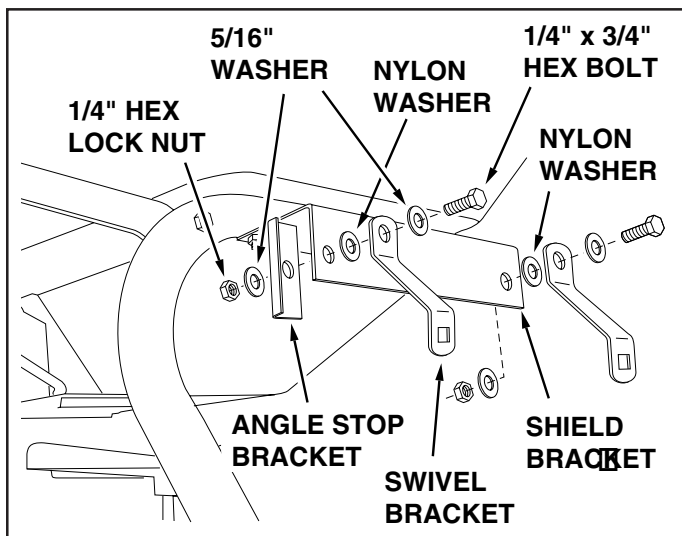

FIGURE 12

28. Assemble the spreader shield to the front swivel brackets using two 1/4" x 3/4" carriage bolts, 5/16" washers and the two 1/4" plastic knobs. See figure 13.
29. Assemble the spreader shield to the rear swivel brackets using two 1/4" x 3/4" hex bolts, four 5/16" washers and two 1/4" hex lock nuts. **Tighten** the locknuts so that the swivel bracket can still pivot freely. See figure 13.

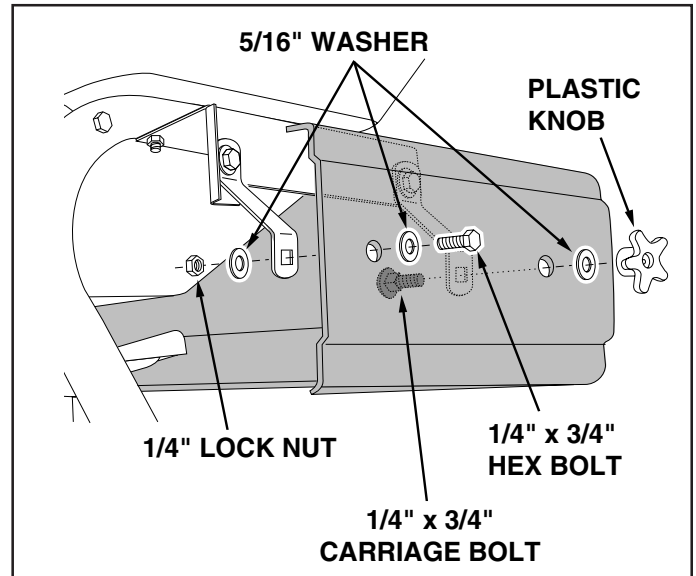

FIGURE 13

30. Place the hopper screen down into the hopper to help break up clumpy material and to prevent large clumps from reaching the bottom of the hopper and clogging the opening. See figure 14.

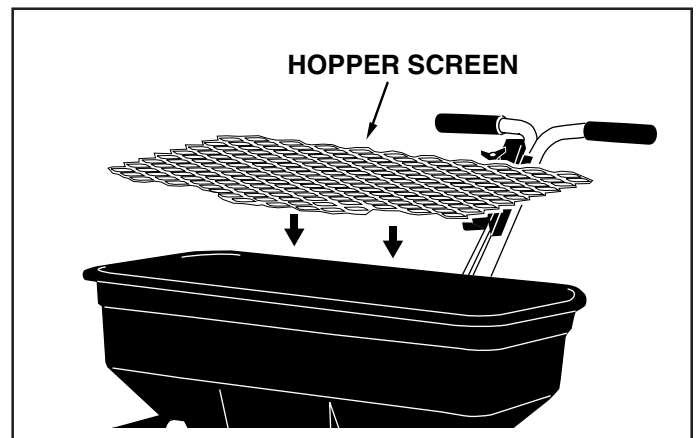

FIGURE 14



# OPERATION

## STARTING THE SPREADER

1. Pull the flow control arm back against the flow control gauge for the "ON" position. This opens the closure plate in the bottom of the hopper and starts the material flow. See figure 15.
2. Always start the spreader in motion before moving the flow control arm to the on position.

## STOPPING THE SPREADER

1. Push the flow control arm forward for the "OFF" position. This closes the closure plate in the bottom of the hopper and stops the material flow. See figure 15.
2. Always move the flow control arm to the off position while the spreader is still in motion.

## SETTING THE FLOW RATE

1. Move the flow control arm to the "OFF" position.
2. Determine the proper flow rate setting by referring to the application charts on page 9 and to the instructions on the chemical package.
3. Loosen the hand knob and move the flow control gauge to the recommended setting and retighten the hand knob. See figure 15.

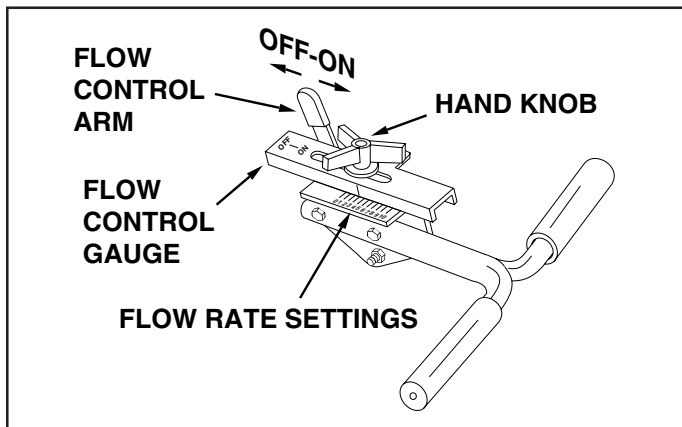

FIGURE 15

## SETTING THE SPREADER SHIELD

### SPREADER SHIELD RAISED

For a normal spread pattern used in open areas, loosen the plastic knob on each side of the shield, raise the shield and retighten the knobs.

### SPREADER SHIELD LOWERED

For a restricted spread pattern when applying material to a confined area or next to sensitive plants, loosen the plastic knob on each side of the shield, lower the shield and retighten the knobs.

## USING THE SPREADER

1. Determine approximate square footage of area to be covered and estimate amount of fertilizer or seed required.
2. With flow control arm in **off position**, set flow rate gauge at number indicated in flow rate chart for light or heavy application rate. Also refer to instructions on bag for manufacturers recommended settings.
3. With the flow control arm set at the off position, fill the hopper with up to 125 pounds of material, breaking up lumpy fertilizer as you fill hopper. The hopper screen helps prevent any large lumps from clogging the opening in the bottom of the hopper.
4. To broadcast, always start the spreader in motion before opening the closure plate.
5. Walk at a brisk pace when spreading. The application charts are based on a ground speed of 3 m.p.h. which equals travelling 100 feet in 23 seconds.
6. Overlap the spread pattern to insure uniform coverage at the edges. Approximate distance between each pass is shown in the application diagrams in figure 16.
7. When using weed control fertilizers make sure the broadcast pattern does not hit evergreen trees, flowers or shrubs. The spreader shield may be lowered to limit the dispersal pattern. Adjust the flow control according to the application chart on page 9.
8. **Do not** allow the spreader to sit stationary with the flow control arm in **ON** position. If fertilizer is accidentally deposited too heavily in a small area, soak the area down thoroughly with a garden hose to prevent burning of the lawn.

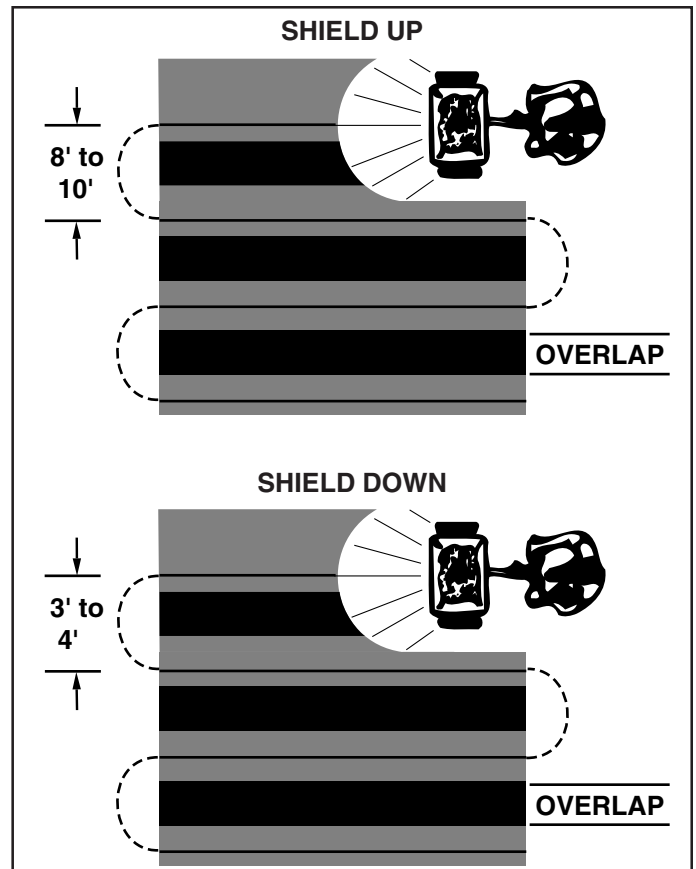

FIGURE 16



**IMPORTANT:** Application rates (shown on chart) are affected by humidity and mixture content of material (granular and pellet). Minor adjustment of the flow rate setting may be necessary to compensate for these variables. The rate chart is calculated for light and heavy application. The faster you walk, the wider the broadcast width. A variation in speed will determine the flow rates and width of broadcast.

**NOTE:** We do not recommend the use of powdered materials due to difficulty in obtaining a satisfactory or consistent broadcast pattern.

APPLICATION CHART (SHIELD UP)		
TYPE MATERIAL	FLOW SETTING 3 MPH (100 FT. IN 23 SEC.)	SPREAD WIDTH IN FEET
FERTILIZER		
Powder	3 - 5	3 - 4
Granular	3 - 5	8 - 10
Pelleted	3 - 5	10 - 12
Organic	6 - 8	6 - 8
GRASS SEED		
Fine	3 - 4	6 - 7
Coarse	4 - 5	8 - 9
ICE MELTER	6 - 8	10 - 12

APPLICATION CHART (SHIELD DOWN)		
TYPE MATERIAL	FLOW SETTING 3 MPH (100 FT. IN 17 SEC.)	SPREAD WIDTH IN FEET
FERTILIZER		
Powder	1 - 3	3 - 4
Granular	1 - 3	3 - 4
Pelleted	1 - 3	3 - 4
Organic	3 - 4	3 - 4
GRASS SEED		
Fine	1 - 3	3 - 4
Coarse	2 - 3	3 - 4
ICE MELTER	2 - 4	3 - 4

## LUBRICATION

1. Apply a little automotive grease to the sprocket and gear.
2. Oil nylon bushings on sprocket shaft. See figure 17.
3. Oil axle/shaft bushing on axle as shown in figure 17.
4. Oil right hand wheel bearing as needed.

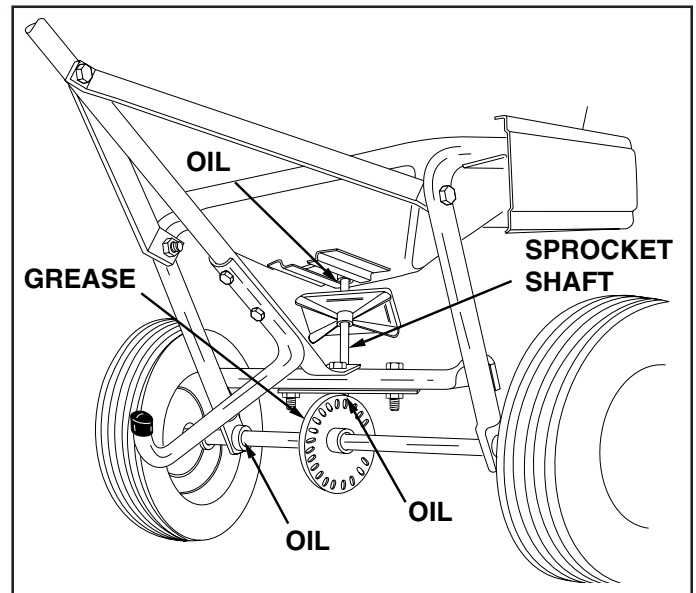

FIGURE 17

## MAINTENANCE & STORAGE

1. Do not store spreader with any material in hopper.
2. Clean your spreader after use. Flush thoroughly with water.
3. If for any reason the axle, gear and sprocket assembly is disassembled, be sure to mark position of parts as they are removed. Drive wheel and sprocket position determine relation direction of spreader plate. With reassembly of gear and sprocket use shim washers as needed for minimum backlash. Add grease to gear and sprocket.
4. If agitator wire becomes damaged or worn it can be replaced. Loosen 3/8" hex nut at top end of sprocket shaft until agitator wire is free. Remove old agitator wire from hole in agitator sleeve and replace with new agitator wire. Position agitator wire so that sprocket shaft turns freely and tighten 3/8" hex nut on top of sprocket shaft. See figure 18.

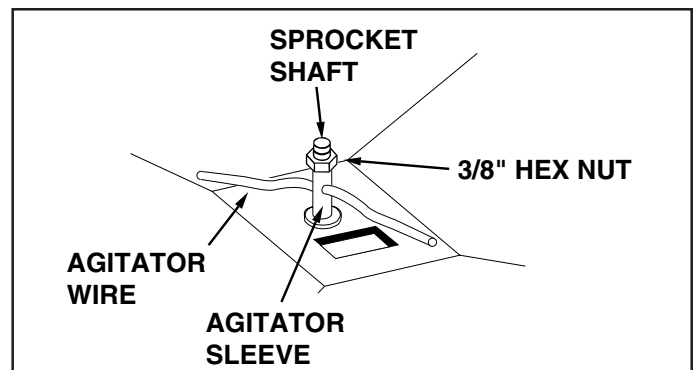

FIGURE 18



# REPAIR PARTS FOR BROADCAST SPREADER MODEL 45-02101-101

REF. NO.	PART NO.	QTY.	DESCRIPTION	REF. NO.	PART NO.	QTY.	DESCRIPTION
1	44466	1	Hopper	37	1509-069	12	Bolt, Hex 1/4-20 x 1-3/4" Lg. *
2	43882	4	Rivet, Stainless	38	43866	2	Bolt, Hex 1/4-20 x 5/8" Lg. Gr. 5*
3	62482	1	Ass'y, Guide Closure	39	1543-069	11	Washer, Nylon
4	44462	1	Tube, Frame	40	43088	9	Washer, Flat 1/4" Std.
5	23753	1	Slide Gate Angle Bracket	41	23755	1	Gage, Flow Control
6	23758	1	Slide Gate Bracket	42	23754	1	Bracket, Flow Control Mount
7	43648	2	Bolt, Hex 1/4-20 x 1-1/2" Lg.*	43	62474	1	Gear Assembly
8	23756	1	Flow Control Link	44	23759	1	Flow Control Arm
9	43013	24	Nut, Hex Lock 1/4-20 Thd. *	45	44101	1	Cotter Pin 3/32" x 3/4" Lg.*
10	43808	1	Tube, Crossover	46	23533	1	Plate, Closure
11	43084	2	Bolt, Hex 5/16-18 x 1-3/4" Lg. Gr. 5	47	43000	1	Spring, Extension
12	43086	2	Lock Washer, 5/16"	48	43848	1	Grip, Flow Control Arm
13	43064	2	Nut, Hex 5/16-18 Thd.*	49	44481	1	Cap, Vinyl
14	44463	1	Tube, Handle (Long)	50	43093	1	Cotter Pin, 1/8" x 101/2" Lg.
15	44456	1	Wheel Ass'y. 14" x 4"	51	43009	4	Washer, 1-5/8" O.D. x 25/32" I.D.
16	44457	1	Wheel Ass'y. (W/Hole) 14" x 4"	52	43849	1	Knob, Plastic 1/4-20 Thd.
17	44464	1	Tube, Handle (Short)	53	44285	2	Bushing, Delrin 3/8" I.D.
18	23752	1	Shaft, Axle	54	43054	1	Bolt, Hex 3/8-16 x 2" Lg. Gr. 5
19	43851	2	Pin, Spring 3/16" Dia. x 1-1/4" Lg.	55	44482	2	Grip, Handle
20	43871	1	Bushing, Axle Shaft	56	43082	3	Nut, Hex Lock 3/8-16 Thd.
21	1540-032	5	Washer, Flat .78" I.D.	57	41576	2	Bolt, Hex 3/8-16 x 1-3/4" Lg. Gr. 5
22	1540-162	1	Washer, Flat 3/4" Std.	58	44465	1	Tube, Leg Stand
23	44798	2	Bearing, Flange	59	43962	1	Optional Vinyl Hopper Cover
24	44494	1	Tube, Spacer	60	44566	1	Spring, Torsion
25	47437	1	Shaft, Impeller	61	43012	7	Bolt, Hex 1/4-20 x 3/4" Lg. Gr. 5
26	04367	1	Spreader Plate	62	46055	1	Pin, Spring 1/8" x 1" Lg.
27	43850	1	Pin, Spring 1/8" Dia. x 5/8" Lg.	63	44950	3	Bolt, Carriage 1/4-20 x 3/4" Lg.
28	44500	1	Spacer, 1" O.D. x 1" Lg.	64	R191111116	17	Washer, Flat 5/16"
29	C-9M5732	2	Rivet, Pop	65	46119	1	Shield, Spreader
30	23766	1	Sleeve, Agitator	66	24125	2	Bracket, Shield
31	43878	1	Wire, Agitator	67	46120	2	Knob, Plastic
32	43070	5	Washer, Flat 3/8"	68	23998	4	Bracket, Swivel
33	44468	1	Sprocket - 6 Tooth	69	23999	2	Bracket, Angle Stop
34	44514	1	Rod, Flow Control	70	47441	1	Screen, Spreader
35	23525	2	Brace, Hitch	71	43015	1	Nut, Hex 3/8-16 Thd.
36	23762	1	Support, Shaft	72	43003	1	Lock Washer, 3/8"
					47438	1	Owner's Manual

**REPAIR PARTS**  
303 West Raymond  
Sullivan, IL. 61951  
(217) 728-8388 / [www.agri-fab.com](http://www.agri-fab.com)